

PDB-6 OUTPUTS

NOTES 1-61

OUTPUTS 65-96 NOT USED

STOPS 1-8 (RANKS 1-8)

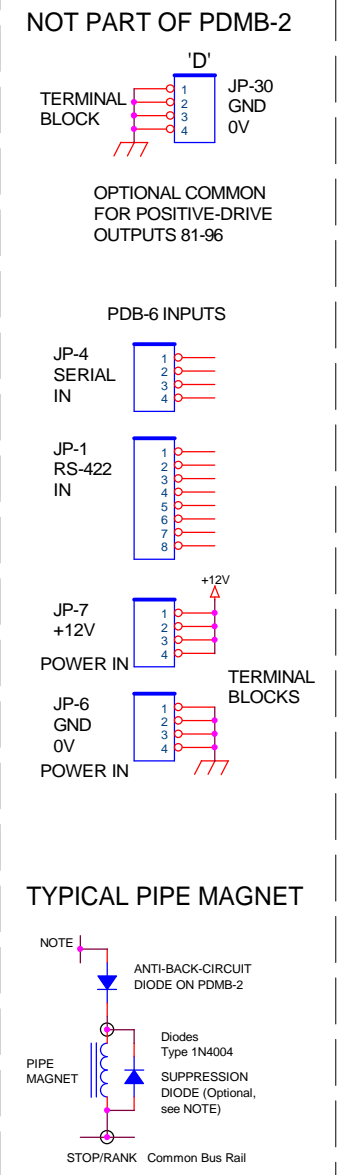
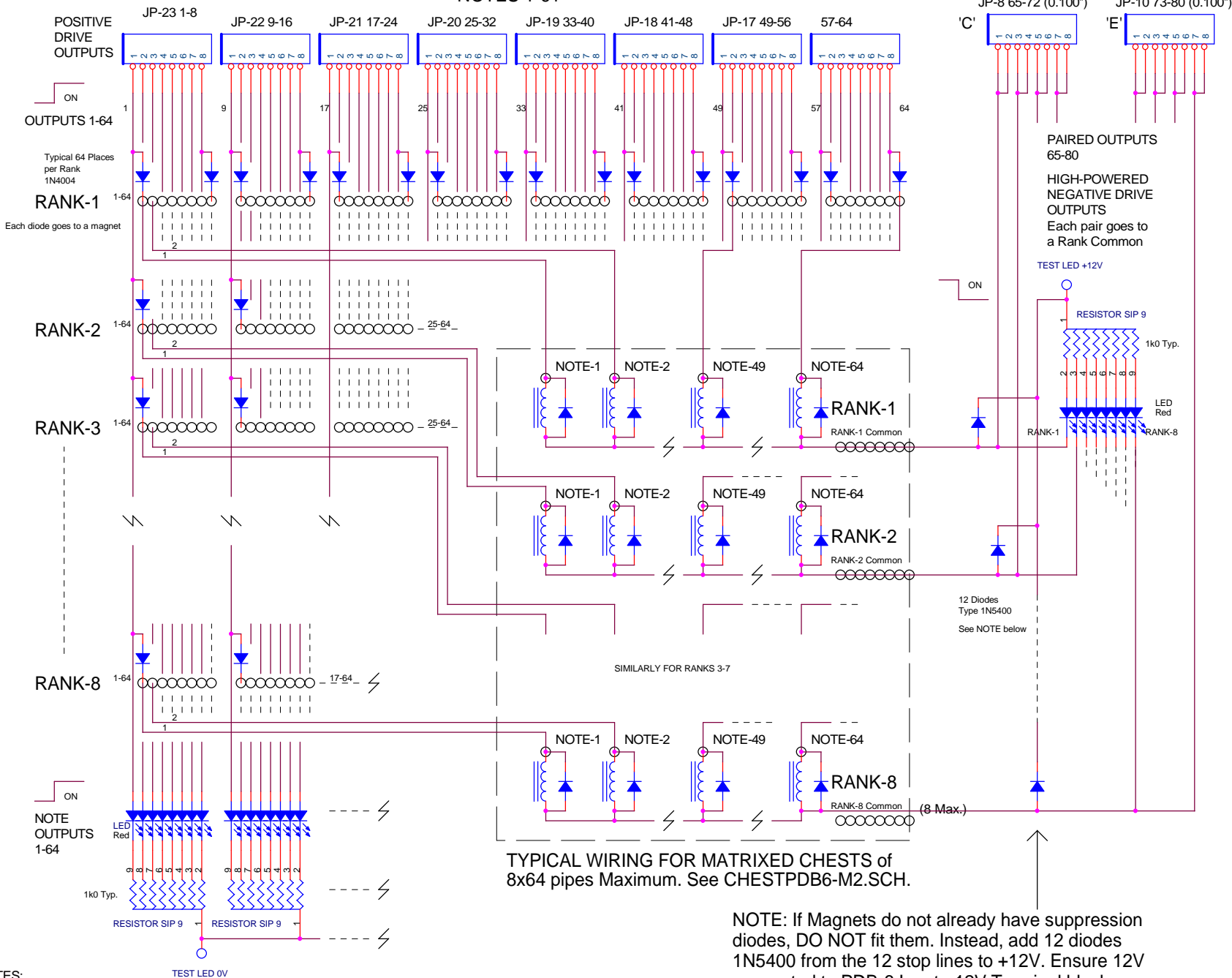

TYPICAL WIRING FOR MATRIXED CHESTS of 8x64 pipes Maximum. See CHESTPDB6-M2.SCH.

NOTE: If Magnets do not already have suppression diodes, DO NOT fit them. Instead, add 12 diodes 1N5400 from the 12 stop lines to +12V. Ensure 12V connected to PDB-6 Input +12V Terminal block.